

MODEL UALSDV/UALSDVH

ALUMINUM SINGLE AND DOUBLE DEFLECTION UNIVERSAL SPIRAL DUCT DIFFUSER

STANDARD INDUSTRY TOLERANCES APPLY. SPECIFICATIONS SUBJECT TO CHANGE WITHOUT NOTICE.

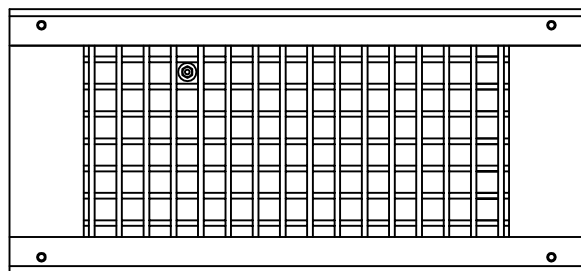

UALSDVH3 SHOWN

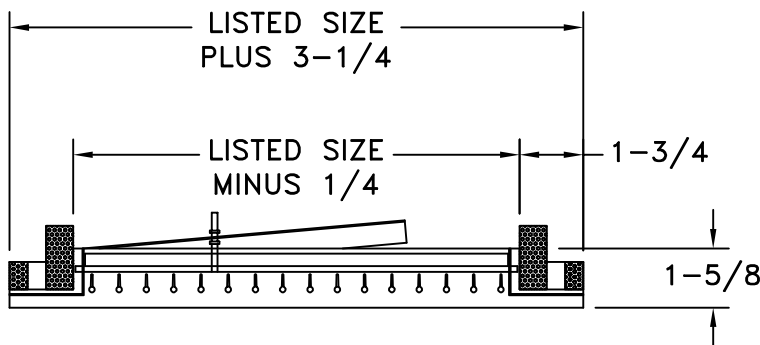
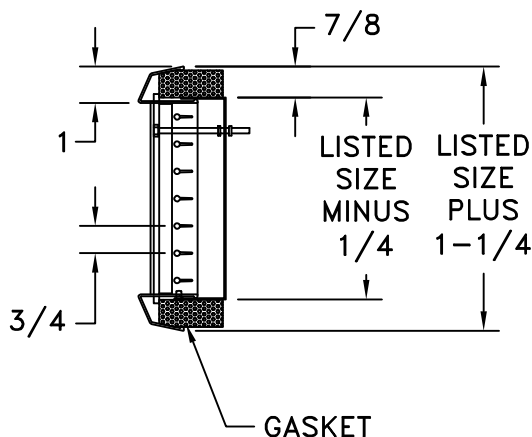

MINIMUM DUCT DIAMETER

HEIGHT	WIDTH								
	10	12	14	16	18	20	24	30	36
3	6	6	6	6	6	6	6	6	6
4	10	10	10	10	10	10	10	10	10
6	12	12	12	12	12	12	12	12	12
8	20	20	20	20	20	20	20	20	20
10	~	~	24	24	24	24	24	24	24
12	~	~	~	~	30	30	30	30	30

Model UALSDV and UALSDVH are single (vertical) and double (vertical and horizontal) deflection spiral duct diffusers which are attached directly to the duct without the need for a saddle. These models eliminate the need for a specific part number for each size of spiral duct since each size offered covers a range of duct diameters as noted. Both Models have adjustable blades and are gasketed on the margin. An optional Air Scoop with face screw adjustment is available for either model. Extruded aluminum construction. Finishes are White and Clear Anodized.

PROJECT: _____

ARCHITECT: _____

ENGINEER: _____

CONTRACTOR: _____

LOCATION: _____

