

MODEL ALEC EXHAUST GRILLE

STANDARD INDUSTRY TOLERANCES APPLY. SPECIFICATIONS SUBJECT TO CHANGE WITHOUT NOTICE.

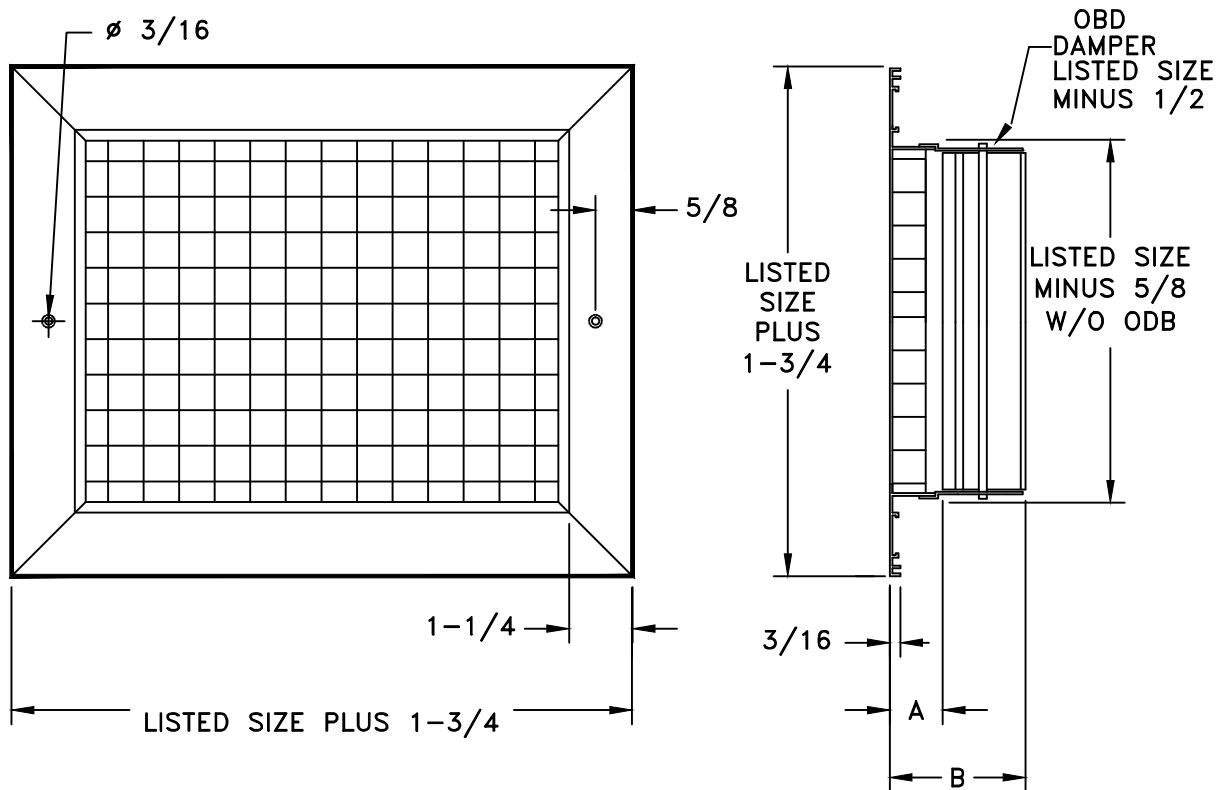

MODEL	GRID CORE DIMENSIONS	A	B
ALEC-5	$1/2 \times 1/2 \times 1/2$	$1-1/4$	$2-1/2$
ALEC-10	$1 \times 1 \times 1$	$1-1/4$	$2-15/16$
ALEC-15	$1/2 \times 1/2 \times 1$	$1-1/4$	$2-15/16$

The Models ALEC-5, -10, -15 are return air grilles that have an aluminum square pattern grid providing maximum free area and minimum see through. Frame 32 has screw holes for surface mounting. Frame 33 does not have screw holes and is sized for lay in T-Bar applications. The optional opposed blade damper (OBD) is offered in steel with aluminum as another option. Standard finish is white.

PROJECT: _____
 ARCHITECT: _____
 ENGINEER: _____
 CONTRACTOR: _____
 LOCATION: _____

